

# FUTURA

**1/6TH SCALE 2WD 90% READY-TO-RUN  
OFF ROAD DUNE BUGGY**



**SET-UP INSTRUCTIONS,  
COMPONENT AND UPGRADE PARTS LISTING**



[www.ftx-rc.com](http://www.ftx-rc.com)





## FTX Futura 1/6th RTR Electric Dune Buggy

Congratulations on the purchase of your FTX 'Futura' electric Dune buggy.

This 1/6th scale model has been factory assembled and all electrics installed and set up to make it the easiest possible introduction to the sport of driving RC cars.



**WARNING:** Read the ENTIRE instruction manual to become familiar with the features of the product before operating. Failure to operate the product correctly can result in damage to the product, personal property and cause serious injury. This is NOT a toy and must be operated with caution and common sense. Failure to operate this product in a safe and responsible manner could result in damage, injury or damage to other property.

This product is not intended for use by children without direct adult supervision. It is essential to read and follow all the instructions and warnings in the manual, prior to assembly, set-up or use, in order to operate correctly and avoid damage or serious injury.

### Safety Precautions and Warnings

- You are responsible for operating this model such that it does not endanger yourself and others, or result in damage to the product or the property of others.
- This model is controlled by a radio which is possibly subject to interference which can cause momentary loss of control so it is advisable to always keep a safe distance to avoid collisions or injury.
- Age Recommendation: 14 years or over. This is not a toy. This product is not intended for use by children without direct adult supervision.

### Carefully follow these directions and warnings, plus those of any additional equipment associated with the use of this model, chargers, ESC and motors, radio etc.

- Never operate your model with low transmitter batteries.
- Always operate your model in an open area away from cars, traffic or people.
- Never operate the model in the street or in populated areas.
- Always keep the vehicle in direct line of sight, you cannot control what you cannot see!
- Keep all chemicals, small parts and anything electrical out of the reach of children.
- Avoid water exposure, moisture causes damage to electronics and may result in the loss of control or permanent damage.
- Avoid injury from high speed rotating parts, gears and axles etc.
- Novices should seek advice from more experienced people to operate the model correctly and meet its performance potential.
- Exercise caution when using tools and sharp instruments.
- Do not put fingers or any objects inside rotating and moving parts.
- Take care when carrying out repairs or maintenance as some parts may be sharp.
- Do NOT touch equipment such as the motor, electronic speed control and battery, immediately after using your model because they can generate high temperatures.
- Always turn on your transmitter before you turn on the receiver in the car. Always turn off the receiver before turning your transmitter off.
- Keep the wheels of the model off the ground, and keep your hands away from the wheels when checking the operation of the radio equipment.
- Prolong motor life by preventing overheat conditions. Undue motor wear can result from frequent turns, rapid change of direction forwards/backwards, continuous stop/starts, pushing/pulling objects, driving in deep sand and tall grass, or driving continuously up hill.

### Contents:

FTX Futura 1/6th RTR Electric Dune Buggy

Transmitter: 2.4ghz steerwheel

### Required to complete:

1 x LiPo Charger

2 x LiPo 7.4V batteries



## Required equipment for operation

### 1. Tools required for building and maintenance:

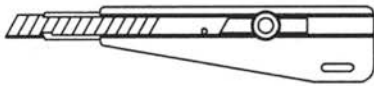

● Hobby knife

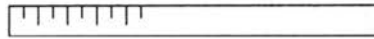

● Precision ruler

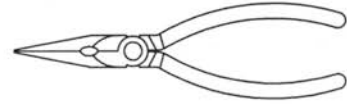

● Needle nose pliers

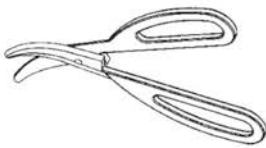

● Lexan scissors

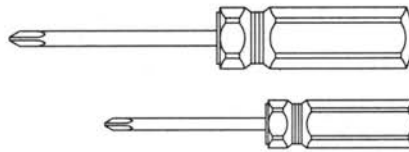

● Flat and Philips screwdriver

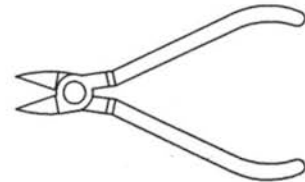

● Wire cutters

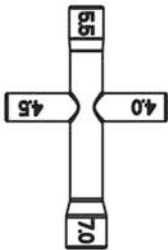

● Cross wrench

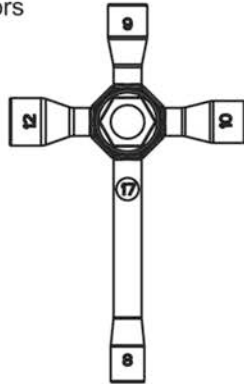

● Cross wrench



● CA glue & rubber cement

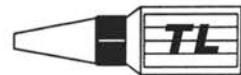

● Thread locking compound



1.5mm



2.0mm

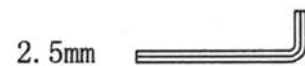

2.5mm

● Hex wrench

## WARNING!

Do not use a power screw driver to install screws into nylon or plastic materials. The fast locking may heat up the screws being installed that may break the molded parts or strip the threads during installation.

### 2. Additional items needed for operation:



3 pcs AA Alkaline batteries for transmitter

## IMPORTANT!

Check that all screws and nuts are tight before each use.



## TO BIND THE RECEIVER TO THE RADIO CONTROLLER

Before running, make sure that the radio controller is bound with the receiver. This has been done at the factory, but if the model is not responding to the controller, it is possible that the controller and receiver are not bound, and you must perform the binding procedure following the instructions below.

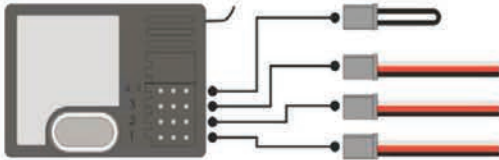

Your 2.4Ghz receiver comes with a binding plug.

Channel 1 to steering servo  
Channel 2 to ESC (or throttle servo)  
Channel 4 for inserting the binding plug.

### LED's Indications:

Flashing sharply: Binding is in process.  
Flashing slowly: No signal  
Being bright on: Binding is completed.  
No Light: Receiver is off or broken.



Please follow the instructions below to bind the receiver with the transmitter.

- 1) Insert the binding plug into Channel 4 on receiver.
- 2) Pressing and holding the PAIR (BIND) button on the transmitter, switch on the transmitter.



Hold the Bind(Pair) key and switch on the power on the radio controller. You must hold the Bind(Pair) within 5 seconds of turning on the receiver on the car.



The green indicator flash, indicating that the binding process is being performed.



Both red and green indicator are bright on, indicating your receiver is bound to your radio controller.

- 3) Switch on the receiver on the car.
- 4) LED flashing, binding operation is automatically in process.
- 5) LED becoming steady on, binding operation is completed.
- 6) To activate Fail Safe function, centre the throttle trigger to set Throttle at 0%.  
(If your car is a nitro car, push the throttle trigger to brake.) Fail Safe Setup is automatically stored in system. *Do not flip the transmitter in process because it may cause your transmitter to store incorrect records.*
- 7) Unplug the binding plug.

## RUNNING YOUR CAR

### 1 TURN ON THE RADIO CONTROLLER

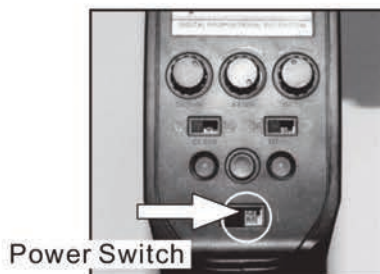

Power Switch

### 2 TURN ON THE RECEIVER ON YOUR CAR

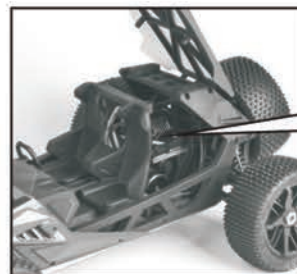

Switch on car





**NOTES:**

- Before using your car, make sure the radio controller has sufficient battery power. If the battery power is too low it can lead to the loss of control of your car.
- Always turn on the remote controller **FIRST**, and then the receiver.

**3 CHECK STEERING PERFORMANCE**

- Ensure good steering performance.



1) To keep the car running in a straight line, do not move the control wheel. (Keep it centered)



2) Turn the control wheel left to allow your vehicle to turn left.

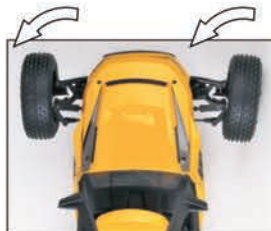

3) Turn the control wheel right to allow your vehicle to turn right.

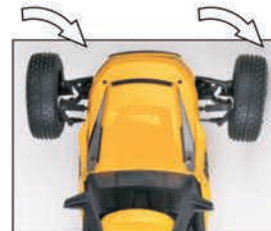

**4 CHECK TRIGGER RESPONSE**

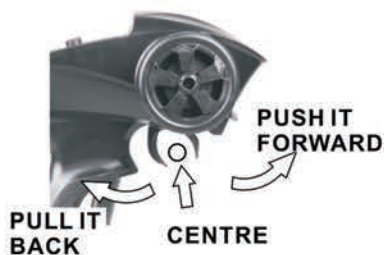

- A. Pull the trigger back to accelerate, release it to decelerate and push it forward to brake.
- B. To stop accelerating your car, release the trigger to Neutral.
- C. Pushing the trigger forward a second time activates the reverse feature.

**5 TO TUNE THE STEERING TRIM**



Gently pull the trigger to allow your car to accelerate slowly. Meantime, tune the steering trim to align the front wheels.



## 6 TO TUNE THE STEERING DUAL RATE CONTROL DIAL



This dial adjusts the overall travel of the steering servo. Push the dial forward for maximum steering. Pull the dial back to reduce the steering level.

- Set the Steering Dual Rate Control Dial to Minimum first. To set the desired steering level increase it again whilst decelerating your vehicle.

## BATTERY INSTALLATION

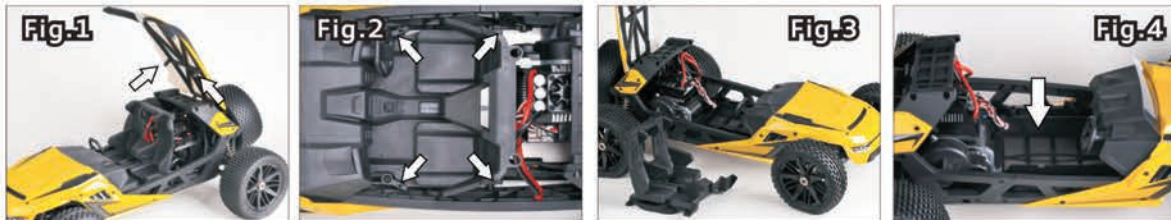

- 1) Release and open the roof by removing the two body clips as shown in Fig. 1
- 2) Unlock the four fasteners with which the cockpit is fixed in place. (See Fig. 2)
- 3) Remove the cockpit from your car. (See Fig. 3)
- 4) Install two batteries to the battery compartment as shown in Fig. 4.

### Note:

For durable performance, we warmly recommend 2pcs of 2S (7.4V) li-Po batteries.  
3s (11.1V) LiPo batteries can be used, but the car must be upgraded with the steel spur gear.

## STOPPING YOUR CAR

### 1 TURN OFF THE RECEIVER ON YOUR CAR

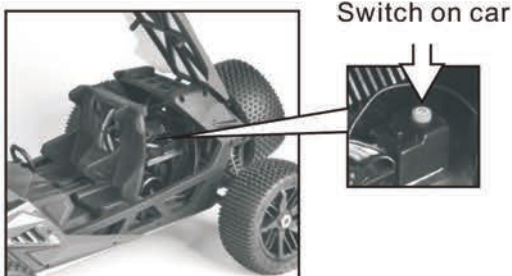

### 2 TURN OFF THE RADIO CONTROLLER

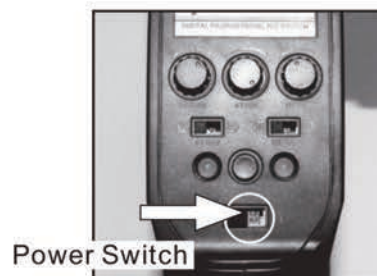

- Always switch off the receiver, and then the radio controller.

### 3 DISCONNECT AND REMOVE BATTERIES

- Do not forget to remove batteries from your car and radio controller when not in use.



## INSTRUCTIONS FOR HOBBYING SPEED CONTROL



Thanks for purchasing our Electronic Speed Controller (ESC). The power system for RC model can be very dangerous, so please read this manual carefully. In that we have no control over the correct use, installation, application, or maintenance of our products, no liability shall be assumed nor accepted for any damages, losses or costs resulting from the use of the product. Any claims arising from the operating, failure of malfunctioning etc. will be denied. We assume no liability for personal injury, consequential damages resulting from our product or our workmanship.

### 01 Warnings

- ★ Ensure all wires and connections are well insulated before connecting the ESC to related devices, as short circuit will damage your ESC.
- ★ Ensure all devices are well connected, in order to prevent poor connections that may cause your vehicle to lose control or other unpredictable issues like damage to the device.
- ★ Read through the manuals of all power devices and chassis and ensure the power configuration is rational before using this unit.
- ★ Do not hold the vehicle in the air and rev it up to full throttle, as rubber tires can "expand" to extreme size or even crack to cause serious injury.
- ★ Stop using the ESC when its casing temperature exceeds 90°C/194°F; Otherwise your ESC will get destroyed and may also get your motor damaged. We recommend setting the "ESC Thermal Protection" to 105°C/221°F (this refers to the internal temperature of the ESC).
- ★ We recommend removing the cooling fan from ESC before exposing vehicle to liquids, and fully dry it right after the use.
- ★ Always disconnect and remove batteries after use, as the ESC will continue to consume current if it's still connected to batteries (even if the ESC is turned off). Long-time contact will cause batteries to completely discharge and result in damage to batteries or ESC. This will not be covered under warranty.

### 02 Features

- ★ Compatible with sensorless brushless motors and sensored brushless motors (only in sensorless mode).
- ★ Fully waterproof design for all weather conditions.
- ★ Super internal switch-mode BEC with switchable voltage of 6V/7.2V and a cont. /peak current of 6A/25A for easily driving big torque servos and high voltage servos.
- ★ Highly reliable electronic switch avoids troubles which may happen to traditional mechanical switch due to dirt, water, dash and etc.
- ★ The built-in spark-proof circuit effectively protects not only battery and ESC connectors from damage but also users from physical injury (to hands) caused by strong electrical sparks produced at the battery and ESC connecting moment.
- ★ Proportional brake with 9 levels of brake amount/maximum brake force and 9 levels of drag brake force.
- ★ 5 levels of acceleration /punch from soft to aggressive for different vehicles, tires and tracks.
- ★ Multiple protections: motor lock-up protection, low-voltage cutoff protection, thermal protection, overload protection, and fail safe.
- ★ Single-button ESC programming and factory reset.
- ★ Advanced programming via portable LED program card.

### 03 Specifications

Model	WP-6BL160-RTR	WP-5BL200-RTR
Cont./Burst Current	160A/1050A	200A/1300A
Motor Supported	Sensored / Sensorless Brushless Motor (only in sensorless mode)	
Cars Applicable	1/6, 1/7th Touring Car, Buggy, Truggy and Truck	1/5th Touring Car, Buggy, Truggy and Truck
Motor Limit	4S LiPo : 5892 size motor, KV ≤ 2000 6S LiPo : 5892 size motor, KV ≤ 1500	6S LiPo : 58110 size motor, KV ≤ 1200 8S LiPo : 58110 size motor, KV ≤ 1000
Battery	9-18 Cells NiMH, 3-6S Lipo	9-24 Cells NiMH, 3-8S Lipo
BEC Output	6V/7.2V Switchable, Continuous Current of 6A (Switch-mode BEC)	
Cooling Fan	Powered by the stable BEC voltage of 6V/7.2V	
Size/Weight	70(L)x56(W)x46.5(H)/240g	93.35 (L)x 58.12 (W)x 47.81 (H)/342g
Programming Port	FAN /PRG Port	

### 04 Begin To Use The New ESC

**WARNING!** This is an extremely powerful brushless motor system. For your safety and the safety of those around you, we strongly recommend removing the pinion gear before. Performing calibration and programming functions with this system, and keeping wheels in the air when you turn on the ESC.

#### 1. Connect the ESC, Motor, Receiver, Battery And Servo

The #A, #B, #C wires of the ESC can be connected with the motor wires freely (without any sequence). If the motor runs in the opposite direction, please swap any two wire connections.

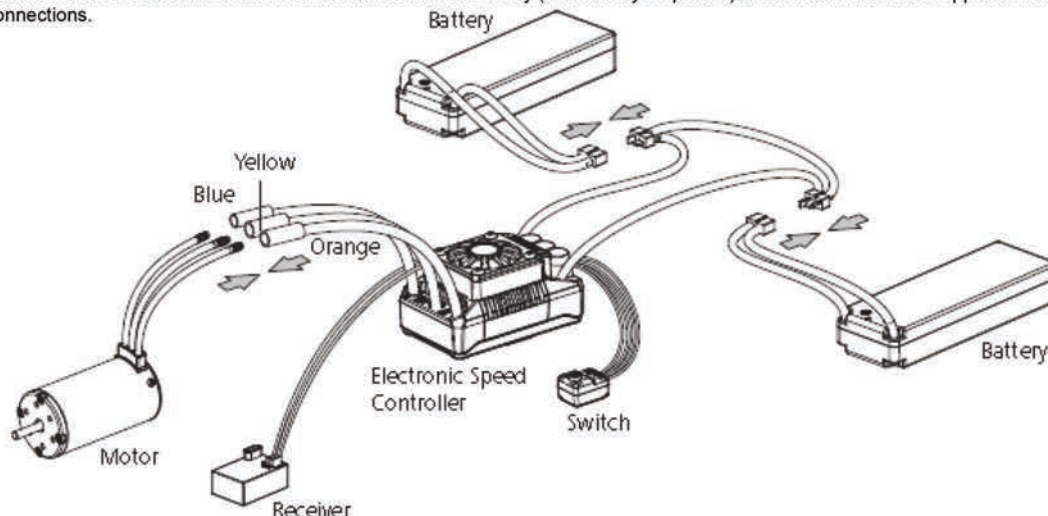

#### 2. Throttle Range Setting (Throttle Range Calibration)

In order to make the ESC match the throttle range, you must calibrate it when you begin to use a new ESC, or a new transmitter, or change the settings of neutral position of the throttle stick, ATV or EPA parameters, etc. The following pictures show how to set the throttle range with a Futaba™ transmitter.

A. Turn on the transmitter, set parameters on the throttle channel like "D/R", "EPA" and "ATL" to 100% and the throttle "TRIM" to 0. For Futaba™ radio



transmitter, the direction of throttle channel shall be set to "REV", while other radio systems shall be set to "NOR". Please ensure the "ABS braking function" of your transmitter must be DISABLED.

- B. Start with transmitter on and the ESC turned off but connected to a battery. Holding the SET button and press the ON/OFF button to turn on the ESC, the RED LED on the ESC starts to flash (the motor beeps at the same time *Note 1*), and then release the SET button immediately. (The ESC will enter the programming mode if the SET button is not released in 3 seconds, then you need to restart from step 1.)

Press and hold the SET button

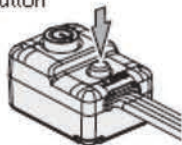

Press the ON/OFF button

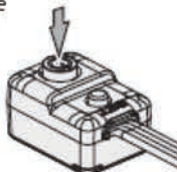

Release the SET button once the LED flashes.

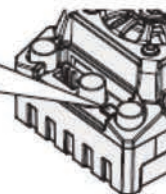

*Note 1: Beeps from the motor may be low sometimes, and you can check the LED status instead.*

- C. Set the neutral point, the full throttle endpoint and the full brake endpoint.

- Leave the throttle trigger at the neutral position, press the SET button, the RED LED dies out and the GREEN LED flashes 1 time and the motor beeps 1 time to accept the neutral position.
- Pull the throttle trigger to the full throttle position, press the SET button, the GREEN LED blinks 2 times and the motor beeps 2 times to accept the full throttle endpoint.
- Push the throttle trigger to the full brake position, press the SET button, the GREEN LED blinks 3 times and the motor beeps 3 times to accept the full brake endpoint.

Move the throttle trigger to the end position of forward and press the SET button.

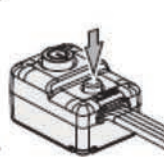

The Green LED flashes once and motor emits "Beep" tone.

Move the throttle trigger to the neutral position and press the SET button.

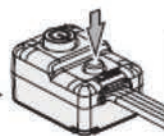

The Green LED flashes twice and motor emits "Beep-Beep" tone.

Move the throttle trigger to the end position of forward and press the SET button.



The Green LED flashes three times and motor emits "Beep-Beep-Beep" tone.

- D. The motor can be started 3 seconds after the ESC/Radio calibration is complete.

### 3. Check LED Status In Normal Running

- RED & GREEN LEDs die out when the throttle trigger is in throttle neutral zone.
- The RED LED turns on solid when your vehicle runs forward. The GREEN LED will also come on when pulling the throttle trigger to the full (100%) throttle endpoint.
- The RED LED turns on solid when you brake the vehicle, the GREEN LED will also come on when pushing the throttle trigger to the full brake endpoint and setting the "brake amount/maximum brake force" to 100%.
- The RED LED turns on solid when you reverse your vehicle.

### 05 Power ON-OFF warnings

- Power ON/OFF:  
(Start with the ESC turned off), press the ON/OFF button to turn on the ESC.  
(Start with the ESC turned on), press and hold the ON/OFF button to turn off the ESC.
- Warning Tones:  
Turn on the ESC in the normal way (that is to turn it on without holding the SET button); the motor will beep the number of LiPo cells you have plugged in. For example, 3 beeps indicate a 3S LiPo, 4 beeps indicate a 4S LiPo, 6 beeps indicate a 6S LiPo, and 8 beeps indicate an 8S LiPo.

### 06 Programmable Items List (The italics texts in the following form are the default settings)

Programmable Items	Option 1	Option 2	Option 3	Option 4	Option 5	Option 6	Option 7	Option 8	Option 9
1. Running Mode	Fwd/Br	<i>Fwd/Rev/Br</i>							
2. LiPo Cells	<i>Auto</i>	2S	3S	4S	6S	8S			
3. Low Voltage Cutoff	Disabled	Auto (Low)	<i>Auto (Intermediate)</i>	Auto (High)					
4. ESC Thermal Protection	<i>105 °C/221 °</i>	125 °C/257 °F							
5. Motor Thermal Protection	<i>Disabled</i>								
6. Motor Rotation	<i>CCW</i>	CW							
7. BEC Voltage	<i>6.0V</i>	7.2V							
8. Max Brake Force	12.50%	25.00%	37.50%	<i>50.00%</i>	62.50%	75.00%	87.50%	100.00%	Disabled
9. Max Reverse Force	<i>25.00%</i>	50.00%							
10. Start Mode (Punch)	Level 1	Level 2	<i>Level 3</i>	Level 4	Level 5				
11. Drag Brake	<i>0%</i>	2%	4%	6%	8%	10%	12%	14%	16%

#### 1. Running Mode:

##### Option 1: Fwd/Br (Forward with Brake)

The vehicle can go forward and brake but cannot reverse in this mode. This mode is usually for racing

##### Option 2: Fwd/Rev/Br (Forward / Reverse with Brake)

This mode provides the braking function, so it's usually for training. "Forward/ Reverse with Brake" mode adopted the "DOUBLE-CLICK" method, that is your vehicle only brakes (won't reverse) when the 1st time you push the throttle trigger forward (away from you) (1st push). If the motor stops when you quickly release the throttle trigger and then re-push the trigger quickly (2nd push), the vehicle will reverse. If the motor does not stop, then your vehicle won't reverse but brake, and you need to push the throttle trigger one more time. The vehicle only reverses after the motor stops. This method is for





preventing vehicle from being accidentally reversed.

**2. LiPo Cells:**

We strongly recommend setting this item manually instead of using the default setting "Auto Calc. (which means calculating the LiPo cells automatically)". The ESC can only identify 3S, 4S, 6S LiPo packs when setting this item to "Auto Calc.". After you power on the ESC, if the battery voltage is below 13.6V, it will be identified as a 3S, if the voltage is from 13.6V to 17.6V, it will be identified as a 4S, if the voltage is from 17.6V to 26.5V, it will be identified as a 6S.

*Note 2:*

*This ESC is not intended for 2S operation. Even if you can set the "LiPo Cells" to 2S, it still does not work.*

*You need to set "LiPo Cells" to "Auto Calc." and "Cutoff Voltage" to "Disabled" if you use a NiMH pack or a 5S LiPo.*

**3. Low Voltage Cut-Off:**

Sets the voltage at which the ESC lowers or removes power to the motor in order to keep the LiPo battery at a safe minimum voltage. The ESC will monitor the battery voltage all the time, it will immediately reduce the power to 50% and cut off the output 10 seconds later when the voltage goes below the cutoff threshold. The RED LED will flash a short, single flash that repeats (☆, ☆, ☆) to indicate the low-voltage cutoff protection is activated. If you use a NiMH pack, then please set the "Cutoff Voltage" to "Disabled".

**4. ESC Thermal/Overheat Protection:**

The ESC will automatically cut off the output and the GREEN LED will flash a short, single flash that repeats (☆, ☆, ☆) when the temperature gets up to the value you preset and activates the ESC thermal protection. The output won't resume until the temperature gets down.

**5. Motor Thermal/Overheat Protection:**

This item has been permanently set to "Disabled" by manufacturer.

**6. Motor Rotation:**

Pull the throttle trigger with the motor shaft faces you, the motor spins counter clockwise if this item is set to CCW; the motor spins clockwise if set to CW. The (A/B/C) wiring order of motors from different manufacturers may vary, so the direction of the motor rotation may be opposite to what you expect. You can adjust the "Motor Rotation" or swap any two (ESC-to-motor) wires if the motor runs in reverse

**7. BEC Voltage:**

**Option 1: 6.0V**

It's applicable to ordinary servos. Do not use this option with high voltage servos; otherwise your servos may not function normally due to insufficient voltage.

**Option 2: 7.2V**

It's applicable to high voltage servos. Do not use this option with ordinary servos; otherwise your servos may be burnt due to high voltage.

**8. Brake Amount/ Max. Brake Force:**

This ESC provides the proportional braking function; the braking effect is decided by the position of the throttle trigger. It sets what percentage of available braking power is applied with full brake. Large amount will shorten the braking time but it will damage your pinion and spur. Please select the most suitable brake amount as per your car condition and your preference.

**9. Reverse Amount/ Max. Reverse Force:**

Different reverse amount will bring different reversing speed. For the safety of your vehicle, we recommend using a low amount.

**10. Start Mode / Punch:**

You can choose the punch from level 1 (very soft) to level 5 (very aggressive) as per the track, tires, grip, your preference and etc. This feature is very useful for preventing tires from slipping during the starting-up process. In addition, "level 4" and "level 5" have strict requirement on battery's discharge capability. It may affect the starting-up if the battery discharges poorly and cannot provide large current in a short time. The car stutters or suddenly loses power in the starting-up process indicating the battery's discharge capability is not good; You need to reduce the punch or increase the FDR (Final Drive Ratio).

**11. Drag Brake:**

Drag brake is the slight braking power produced when releasing the throttle trigger to neutral zone. This gently slows the vehicle down when you let off the trigger; it can provide a better cornering approach. (Attention! Drag brake will consume much power, so apply it cautiously.)

**07 Program The ESC**

**1. Program the ESC with the SET button on the ESC**

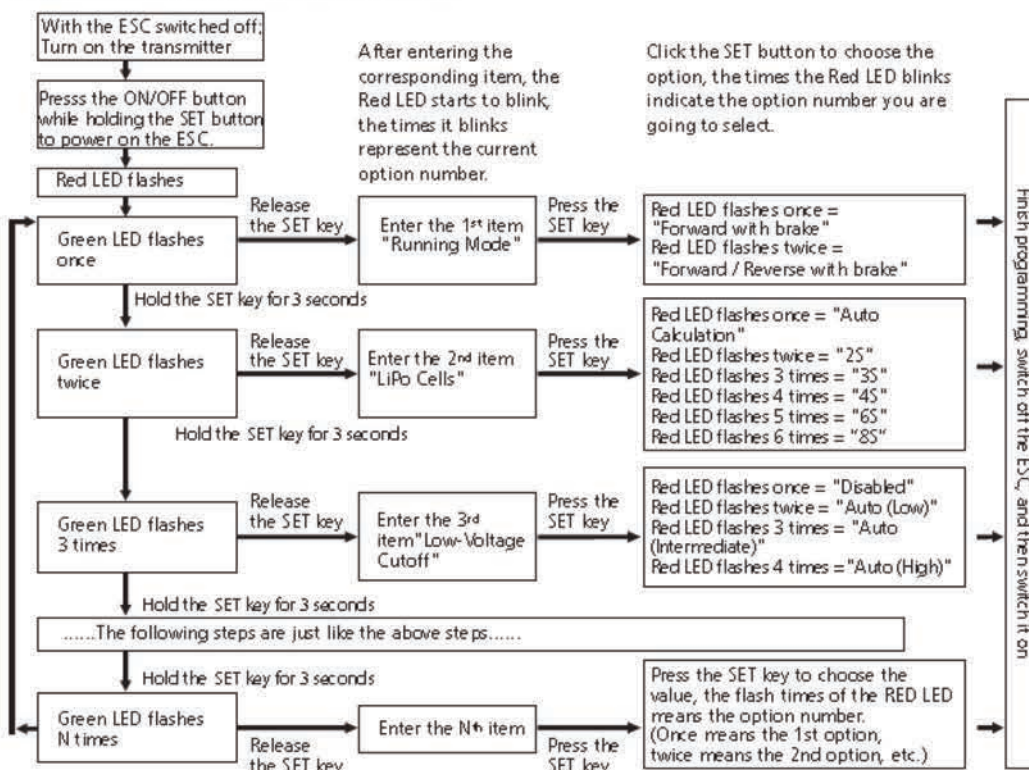



- 1) In the program process, the motor will emit "Beep" tone when the LED is flashing.
- 2) We use a long time flash and long "Beep---" tone to represent number "5" for easily identify the items of the big number. "A long time flash" (Motor sounds "B---") = the No. 5 item, "A long time flash + a short time flash" (Motor sounds "B--B") = the No. 6 item, "A long time flash + 2 short times flash" (Motor sounds "B---BB") = the No. 7 item, "A long time flash + 3 short times flash" (Motor sounds "B---BBB") = the No. 8 item, "A long time flash + 4 short times flash" (Motor sounds "B---BBBB") = the No. 9 item

## 2. Program the ESC with the LED program box

The portable program card is an optional accessory applicable for field use. Its friendly interface makes the ESC programming easy and quick. Before the programming, you need to connect your ESC and the program card via a cable with two JR male connectors, and then turn on the ESC; all programmable items will show up a few seconds later. You can select the item you want to program and the setting you want to choose via "ITEM" & "VALUE" buttons on the program card and then press the "OK" button to save all new settings to your ESC.



The programming port of this ESC is also the fan port, so you need to unplug the fan first and then plug (one end of) the programming cable in the PRG/FAN port and the other end (of the programming cable) in the ESC port on the LED program box. Please don't use the throttle control cable (also called Rx cable) on the ESC to connect the program card/box, otherwise the program card/box won't function.

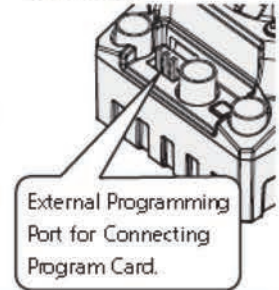

## 08 Factory Reset

### 1) Restore the default values with the SET button

Press and hold the SET button for over 3 seconds anytime when the throttle trigger is at the neutral position (except during the ESC calibration and programming) can factory reset your ESC. RED & GREEN LEDs flash simultaneously indicating you have successfully restored all the default values within your ESC. Once you power the ESC off, and then back on, your settings will be back in the default mode.

### 2) Restore the default values with the LED program card

After connecting the program card to the ESC, press the "RESET" button and the "OK" button to factory reset your ESC.

## 09 Trouble Shooting

Trouble	Possible Reason	Solution
After power on, motor doesn't work, and the cooling fan doesn't work	No power was supplied to the ESC.	Check if all ESC & battery connectors have been well soldered or firmly connected.
	The ESC switch was damaged	Replace the broken switch.
After power on, motor can't work, but emits "beep-beep-, beep-beep-" alert tone. (Every "beep-beep-" has a time interval of 1 second )	Input voltage is abnormal, too high or too low	Check the voltage of the battery pack
After the ESC was powered on and finished LiPo cells detection (the GREEN LED flashed N times), and then the RED LED flashed rapidly.	The ESC didn't detect any throttle signal.	Check if the throttle wire is reversely plugged in or in the wrong channel and if the transmitter is turned on.
	The neutral throttle value stored on your ESC is different from the value stored on the transmitter	Re-calibrate the throttle range after you release the throttle trigger to the neutral position.
The motor runs in the opposite direction when it is accelerated	The (ESC-to-motor) wiring order was incorrect.	Swap any two wire connections between the ESC and the motor.
	Your chassis is different from popular chassis.	
The motor suddenly stops running while in working state	The throttle signal is lost	Check the transmitter and the receiver Check the signal wire from the throttle channel of your receiver
	The ESC has entered the Low Voltage Protection Mode or Over-heat Protection Mode	Red LED flashing means Low Voltage. Green LED flashing means Over-heat
The motor stuttered but couldn't start.	Some soldering between the motor and the ESC was not good.	Check all soldering points, please re-solder if necessary.
	The ESC was damaged (some MOSFETs were burnt).	Contact the distributor for repair or other customer services.
The vehicle could run forward (and brake), but could not reverse.	The throttle neutral position on your transmitter was actually in the braking zone.	Re-calibrate the throttle neutral position. No LED on the ESC will come on when the throttle trigger is at the neutral position.
	Set the "Running Mode" improperly.	Set the "running mode" to "Forward/Reverse with Brake".
	The ESC was damaged.	Contact the distributor for repair or other customer services.
The car ran forward/backward slowly when the throttle trigger was at the neutral position.	The neutral position on the transmitter was not stable, so signals were not stable either.	Replace your transmitter
	The ESC calibration was not proper.	Re-calibrate the throttle range or fine tune the neutral position on the transmitter.
The LED program card kept display 3 short lines (- - -) after you connected it to your ESC.	The programming card/box was connected to the ESC via the throttle control cable (Rx cable).	It is wrong to use the Rx cable to connect programming card/box. The programming port of this ESC is also the fan port, so please connect the ESC and programming card/box by plugging the programming cable into the fan port.
When pressing the SET button to set the throttle neutral position, the GREEN LED didn't flash and no beep was emitted, or you were unable to set the full throttle endpoint and the full brake endpoint after the neutral position was accepted.	The ESC throttle cable wasn't plugged in the correct channel on the receiver.	Plug the throttle cable into the throttle (TH) channel on your receiver.
	The ESC throttle cable was reversely plugged in.	Plug in the throttle cable properly by referring to relevant mark shown on your receiver.



## MAINTAINING YOUR CAR

After running your car, perform the following procedures regularly to maintain your car's performance.

- Inspect your car for any obvious damage.
- Check the gears for wear, debris or broken/slipping teeth.
- Check the wheels and tighten the wheel screws properly.
- Check for loose screws in the chassis.
- Check the wiring for frayed or damaged wires or connectors.
- Always disconnect and remove the battery when not in use.
- Check all batteries.
- Keep the chassis clean and free of sand, dust, moisture and any other debris.  
Remove and clean the motor if necessary. (Never attempt to re-assemble the motor, you will damage it and void the warranty).
- Clean the car body with a soft lint-free cloth.
- Remove all batteries from the car when not in use.

## TROUBLESHOOTING

A. The vehicle does not work at all.

1. Check to see if radio controller and car are on.
2. Check to see if radio controller and receiver are properly bound.
3. Adjust throttle trim on the radio controller
4. Replace batteries.

B. The vehicle runs slow.

1. Replace or charge the battery pack and/or the radio batteries.
2. Make sure the vehicle is geared properly and the pinion and spur gear are over tightened.
3. Clean all bushings or ball bearings.
4. Check for stripped or dirty gears.

C. The throttle works, but not the steering.

1. Check if the servo feels jammed, try centering carefully it by hand.
2. Check all the steering linkage for any damage.

D. It steers, but no throttle control.

1. Adjust the throttle trim.
2. Replace or charge the battery pack and/or the radio batteries.

E. The vehicle runs noisily.

1. Check gear mesh between spur gear and pinion.
2. Check for stripped and/or dirty gears.
3. Clean and oil bushings or ball bearings.



## LIST FOR REPLACEMENT PARTS

**FTX7665**



Aluminum Chassis

**FTX7662**



Motor Mount

**FTX7663**



Motor Guard Plate

**FTX7664**



Dogbones

**FTX7669**



Aluminum Oil Filled Shocks(Front)

**FTX7670**



Aluminum Oil Filled Shocks(Rear)

**FTX7671**



Front Wheel Axles

**FTX7672**



Rear Wheel Shafts

**FTX7673**



Diff. Outdrive Cups

**FTX7674**



Steering Posts

**FTX7675**



Steering Post Barrel+Load Spring

**FTX7676**



Spur Gear Shaft

**FTX7677**



Diff. Idle Gear Shaft

**FTX7678**



Spur Gear Slipper Spacer

**FTX7679**



Suspension Inside Pins (Front 2P /Rear 2P)+Suspension Outside Pins ( 4P)

**FTX7680**



Front/Rear Upper Links

**FTX7681**



Steering Links

**FTX7682**



Diff. Main Gear

**FTX7683**



Diff. Idle Gear

**FTX7684**



Diff. Drive Gear

**FTX7685**



Diff. Bevel Gears/Pinion Gears

**FTX7686**



Steering Ackerman Plate+Pads

**FTX7687**



Steering Hub Braces (Left/Right)

**FTX7688**



Suspension Braces

NOTES: THE IMAGES OF THE PARTS MAY VARY FROM YOUR ACTUALLY RECEIVED PARTS.



## LIST FOR REPLACEMENT PARTS

<p><b>FTX7689</b></p>  <p>Slipper Springs</p>	<p><b>FTX7690</b></p>  <p>Wheel Hex. /Wheel Hex. Lock</p>	<p><b>FTX7691</b></p>  <p>Diff. Bevel Gear Open Pins</p>	<p><b>FTX7692</b></p>  <p>Gear Pins A <math>\phi 2.5 \times 13</math> (4P) Gear Pins B <math>\phi 3 \times 10.8</math> (4P) Slipper Clutch Pins <math>\phi 3 \times 15.8</math> (4P)</p>
<p><b>FTX7693</b></p>  <p>Wheel Hex. Pins (<math>\phi 2.5 \times 16.8</math>)</p>	<p><b>FTX7694</b></p>  <p>Diff Shims A (<math>\phi 6.2 \times 20.5 \times 0.3</math>) 4P Diff Shims B (<math>\phi 3 \times 9.5 \times 0.3</math>) 8P Shims C (<math>\phi 2.7 \times 5.5 \times 0.5</math>) 4P</p>	<p><b>FTX7695</b></p>  <p>Steering Bushes</p>	<p><b>FTX7696</b></p>  <p>Steering Adjustable Ring</p>
<p><b>FTX7697</b></p>  <p>Gear Box Plugs</p>	<p><b>FTX7698</b></p>  <p>Slipper Clutch Assembly</p>	<p><b>FTX7699</b></p>  <p>Car Body Overlays</p>	<p><b>FTX7700</b></p>  <p>Suspension Lower Arms (Fr. &amp; Rr.)</p>
<p><b>FTX7701</b></p>  <p>Shock Towers</p>	<p><b>FTX7702</b></p>  <p>Side Framework Mount</p>	<p><b>FTX7703</b></p>  <p>Steering Assmibly +Rear Spare Wheel Rack</p>	<p><b>FTX7704</b></p>  <p>Gear Box Housing</p>
<p><b>FTX7705</b></p>  <p>Steering Top Plate+ Suspension Braces</p>	<p><b>FTX7706</b></p>  <p>Front Hubs+Rear Hubs</p>	<p><b>FTX7707</b></p>  <p>Steering Hubs</p>	<p><b>FTX7708</b></p>  <p>Spur Gear + Diff. Housing</p>
<p><b>FTX7709</b></p>  <p>Servo Retainer+Bumper Braces</p>	<p><b>FTX7710</b></p>  <p>Side Mount</p>	<p><b>FTX7711</b></p>  <p>Battery Compartment+Spur Gear Box Housing</p>	<p><b>FTX7712</b></p>  <p>Bumper + Bumper Brace</p>

NOTES: THE IMAGES OF THE PARTS MAY VARY FROM YOUR ACTUALLY RECEIVED PARTS.



## LIST FOR REPLACEMENT PARTS

**FTX7713**

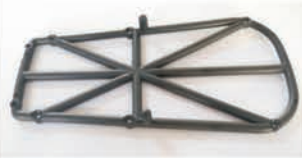

Roof

**FTX7714**



Cockpit Bottom+Hood

**FTX7715**



Cockpit Metre Unit

**FTX7716**



Cockpit Chair

**FTX7717**



Front Upper/Rear Upper/Steering  
/Servo Link Ends

**FTX7718**



Front Wheel Rims

**FTX7719**



Rear Wheel Rims

**FTX7720**



Front Pin Tires (w/Sponge  
Inserted)

**FTX7721**



Rear Pin Tires (w/Sponge  
Inserted)

**FTX7722**



Front Pin Wheels Complete

**FTX7723**



Rear Pin Wheels Complete

**FTX7724**



Concept Sand Tire, w/Sponge  
Inserted(Fr./Rr.)

**FTX7725**



Concept Sand Wheels Complete  
(Fr./Rr.)

**FTX7726**



Ball Stud. φ6.8

**FTX7727**



Ball Stud. φ4.8\*9

**FTX7728**



Step Ball Stud. φ4.8\*7.8

**FASTM3**



Lock Nut M3

**FASTM4**



Lock Nut M4

**FTM5F**



Flange Head Lock Nut M5

**FTBB24**



Ball Bearings 10\*19\*5mm

**FTX7737**



Perforated Ball. φ5.8\*6.8

**FASTM2.5**



Lock Nut M2.5

**FAST213**



Body Clip A/B(Big)

**FAST212**



















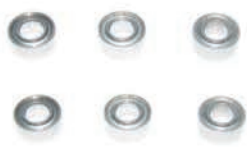



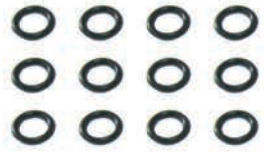

Body Clip A/B(Small)

NOTES: THE IMAGES OF THE PARTS MAY VARY FROM YOUR ACTUALLY RECEIVED PARTS.



## LIST FOR REPLACEMENT PARTS

<p><b>FTBB18</b></p>  <p>Ball Bearings 6*10*3mm</p>	<p><b>FTX7738</b></p>  <p>Ball Stud. <math>\phi</math> 5.8</p>	<p><b>FTBB20</b></p>  <p>Ball Bearings 8*16*5mm</p>	<p><b>FTX6662</b></p>  <p>E-Clip 4mm</p>
<p><b>FTX8565</b></p>  <p>E-Clip 3mm</p>	<p><b>FTX8568</b></p>  <p>Zip Tie (Big)</p>	<p><b>FTX8567</b></p>  <p>Zip Tie (Small)</p>	<p><b>FTX7729</b></p>  <p>E-Clip 5mm</p>
<p><b>FTX7730</b></p>  <p>Ball Bearings 6*12*3mm</p>	<p><b>FTX7731</b></p>  <p>Brushless ESC (160A)</p>	<p><b>FTX7732</b></p>  <p>Brushless Motor (Type 4076, KV 2350)</p>	<p><b>FTX7733</b></p>  <p>Gyroscope</p>
<p><b>FTX7734</b></p>  <p>15KG Steering Servo</p>	<p><b>FTX7735</b></p>  <p>Diff. O-Ring</p>	<p><b>FTX77360</b></p>  <p>Car Body (Yellow)+Front Window Shield</p>	<p><b>FTX7739</b></p>  <p>Motor Pinion</p>
<p><b>FTX7750</b></p>  <p>Hex. Recessed Pan Head Screws (TMH03*8mm)</p>	<p><b>FTX7751</b></p>  <p>Hex. Recessed Pan Head Screws (TMH03*10mm)</p>	<p><b>FTX7752</b></p>  <p>Hex. Recessed Pan Head Screws (TMH03*12mm)</p>	<p><b>FTX7753</b></p>  <p>Hex. Recessed Pan Head Screws (TMH03*18mm)</p>
<p><b>FTX7754</b></p>  <p>Hex. Recessed Pan Head Screws (TMH03*30mm)</p>	<p><b>FTX7755</b></p>  <p>Hex. Recessed Pan Head Screws (TMH03*25mm)</p>	<p><b>FTX7756</b></p>  <p>Hex. Recessed Pan Head Screws (TMH04*4mm)</p>	<p><b>FTX7757</b></p>  <p>Hex. Recessed Pan Head Screws (TMH04*8mm)</p>

NOTES: THE IMAGES OF THE PARTS MAY VARY FROM YOUR ACTUALLY RECEIVED PARTS.



## LIST FOR REPLACEMENT PARTS

<p><b>FTX7758</b></p>  <p>Hex. Recessed Pan Head Screws (TMH04*12mm)</p>	<p><b>FTX7759</b></p>  <p>Hex. Recessed Pan Head Screws (TMH04*16mm)</p>	<p><b>FTX7760</b></p>  <p>Hex. Recessed Pan Head Screws (TMH04*23mm)</p>	<p><b>FTX7761</b></p>  <p>Hex. Recessed Pan Head Self Tapping Screws (TBH04*10mm)</p>
<p><b>FTX7762</b></p>  <p>Hex. Recessed Pan Head Self Tapping Screws (TBH04*12mm)</p>	<p><b>FTX7763</b></p>  <p>Hex. Recessed Pan Head Self Tapping Screws (TBH04*16mm)</p>	<p><b>FTX7764</b></p>  <p>Hex. Recessed Pan Head Self Tapping Screws (TBH04*18mm)</p>	<p><b>FTX7765</b></p>  <p>Hex. Recessed Pan Head Self Tapping Screws (TBH04*25mm)</p>
<p><b>FTX7766</b></p>  <p>Hex. Recessed Countsunk Screws (FMH03*10mm)</p>	<p><b>FTX7767</b></p>  <p>Hex. Recessed Countsunk Screws (FMH03*16mm)</p>	<p><b>FTX7768</b></p>  <p>Hex. Recessed Countsunk Screws (FMH03*25mm)</p>	<p><b>FTX7769</b></p>  <p>Hex. Recessed Countsunk Self Tapping Screws (FBH04*12mm)</p>
<p><b>FTX7770</b></p>  <p>Hex. Recessed Countsunk Self Tapping Screws (FBH04*18mm)</p>	<p><b>FTX7771</b></p>  <p>Hex. Recessed Countsunk Self Tapping Screws (FBH04*25mm)</p>	<p><b>FTX7772</b></p>  <p>Hex. Recessed Countsunk Screws (FMH04*10mm)</p>	<p><b>FTX7773</b></p>  <p>Hex. Recessed Countsunk Screws (FMH04*18mm)</p>
<p><b>FTX7774</b></p>  <p>Cross Recessed Flange Head Self Tapping Screws (PWITH03*10mm)</p>	<p><b>FTX7775</b></p>  <p>Hex. Recessed Set Screws (M3*10)</p>	<p><b>FTX7776</b></p>  <p>Hex. Recessed Set Screws (M4*4)</p>	<p><b>FTX7777</b></p>  <p>Hex. Recessed Set Screws (M4*8)</p>
<p><b>FTX7778</b></p>  <p>Cross Recessed Countsunk Self Tapping Screws (KB2.6*14mm)</p>	<p><b>FTX7779</b></p>  <p>Hex. Recessed Countsunk Screws (FMH03*22mm)</p>	<p><b>FTX7780</b></p>  <p>Hex. Recessed Pan Head Screws (TMH03*21mm)</p>	<p><b>ET1071</b> 2.4GHz Transmitter</p>  <p><b>ET1091</b> 2.4GHz Receiver</p>

NOTES: THE IMAGES OF THE PARTS MAY VARY FROM YOUR ACTUALLY RECEIVED PARTS.





# EXPLODED VIEW

DIFF. ASSEMBLY-1

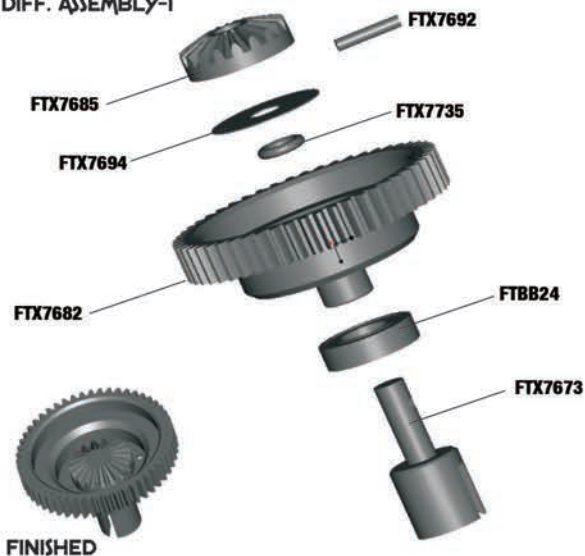

DIFF. ASSEMBLY-2

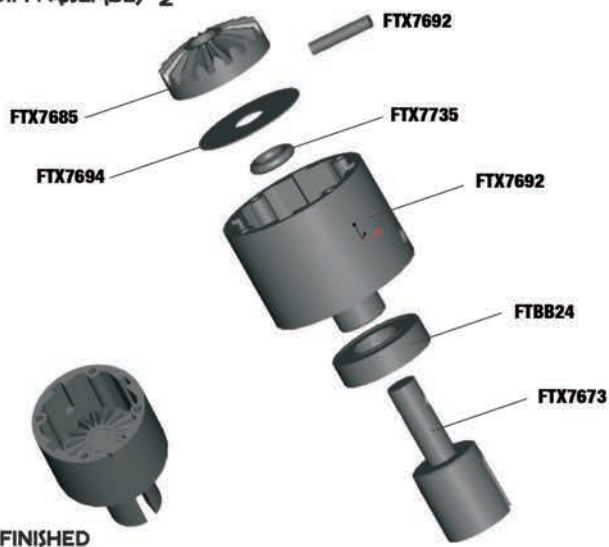

DIFF. ASSEMBLY-3

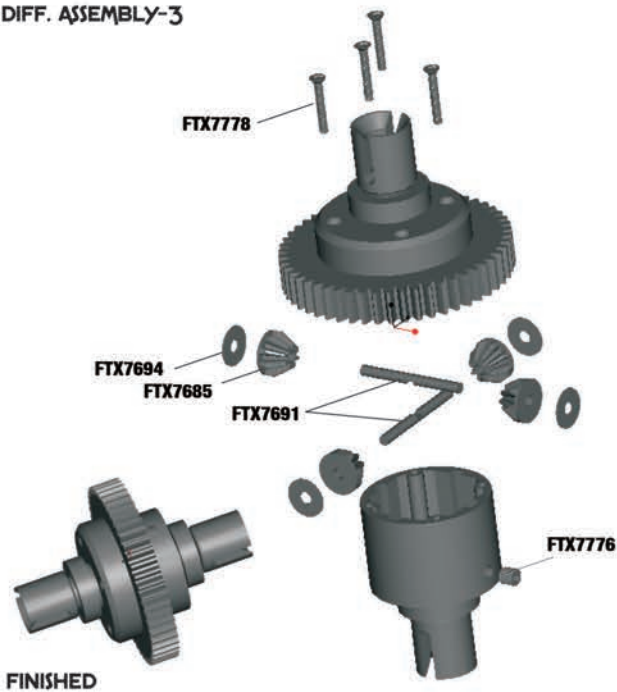

GEAR ASSEMBLY

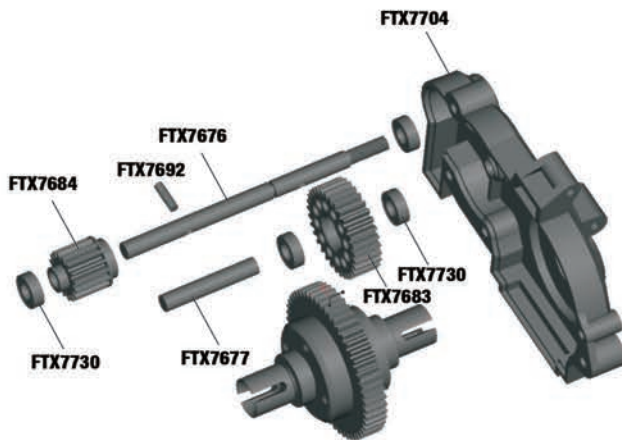

GEAR BOX ASSEMBLY

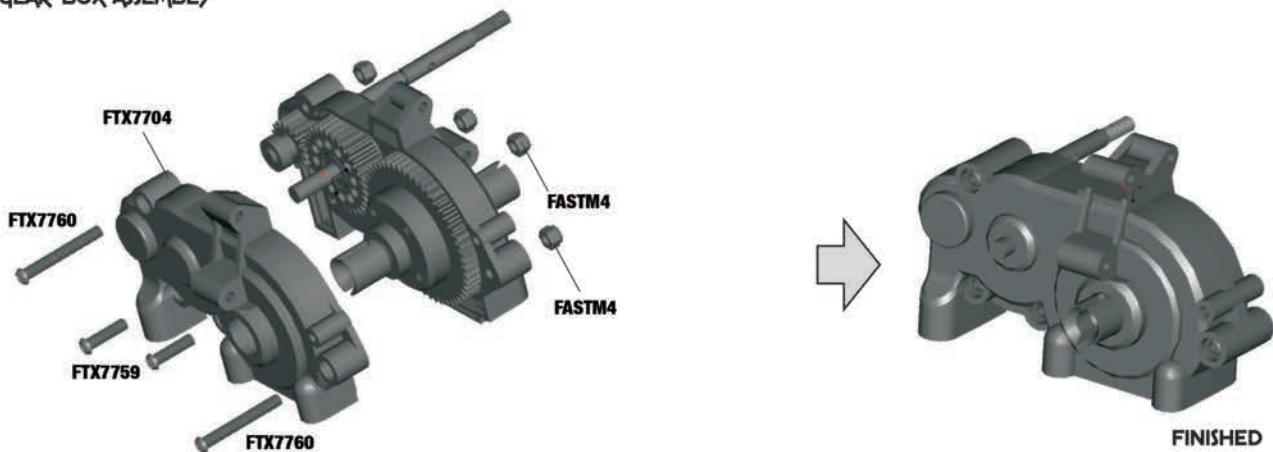



# EXPLODED VIEW

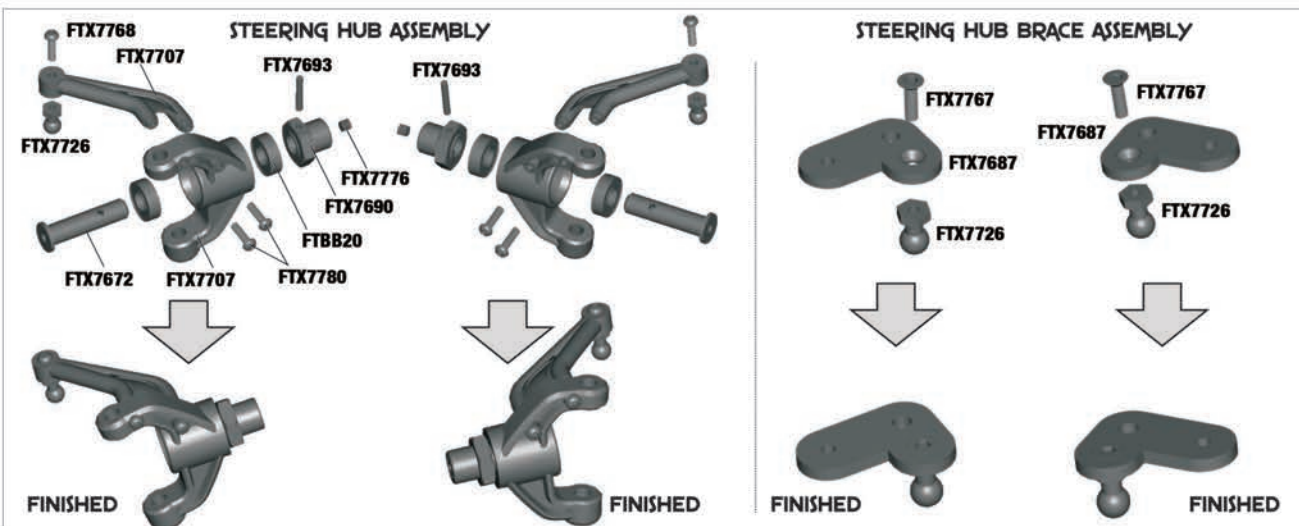
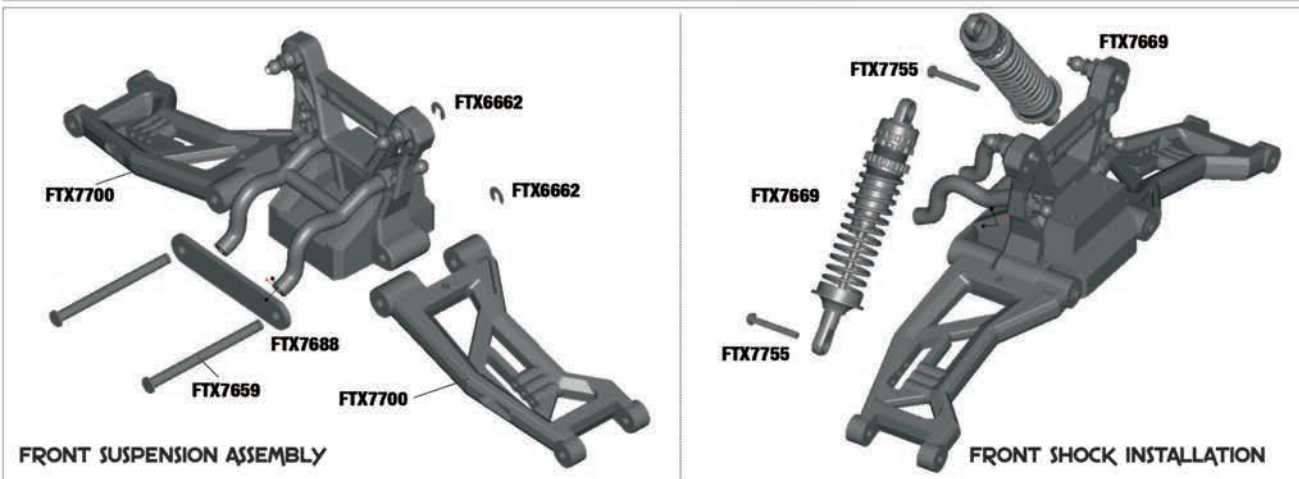
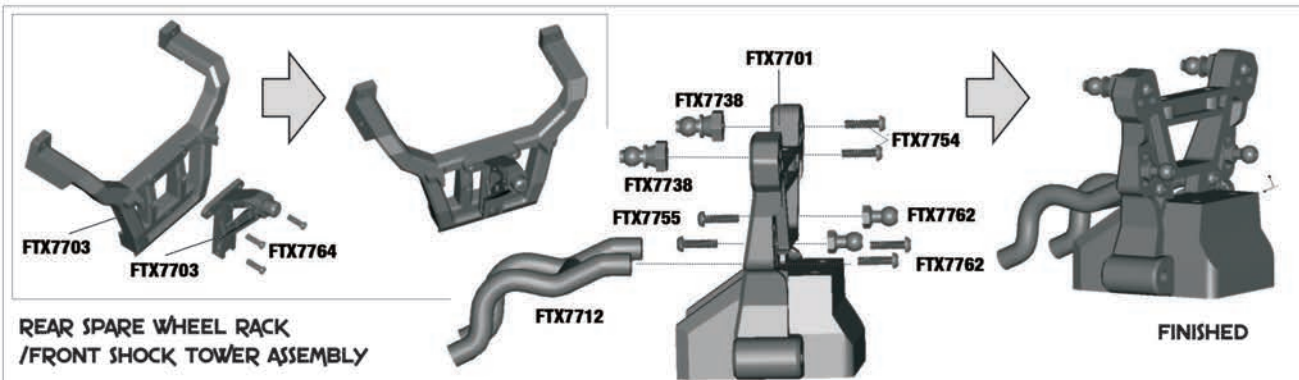
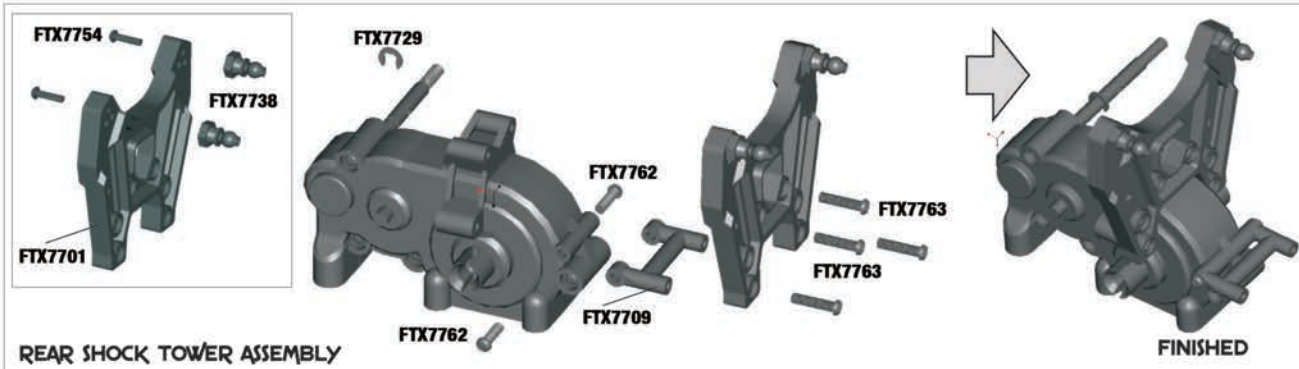



# EXPLODED VIEW

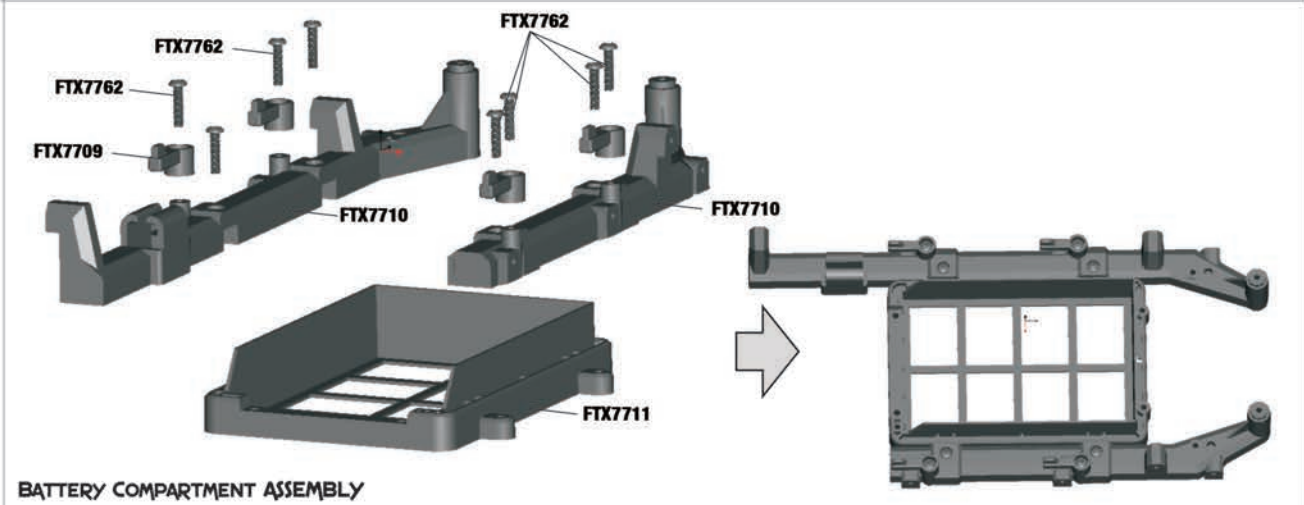
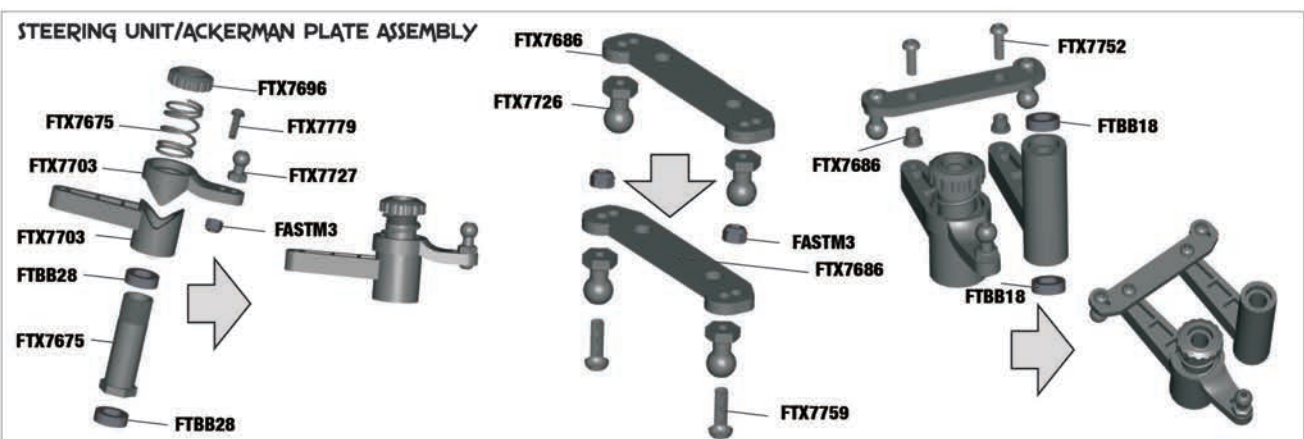
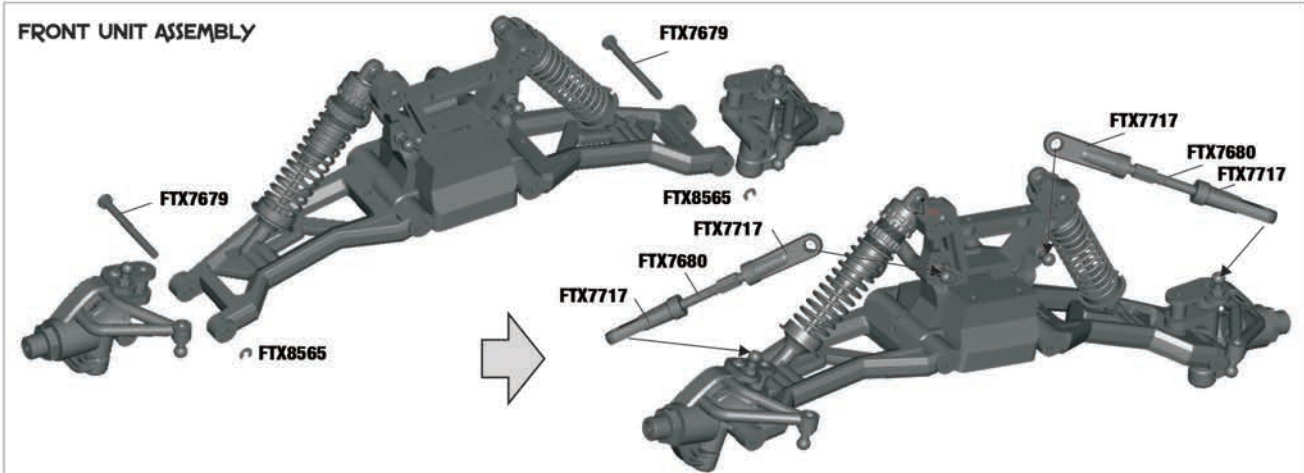
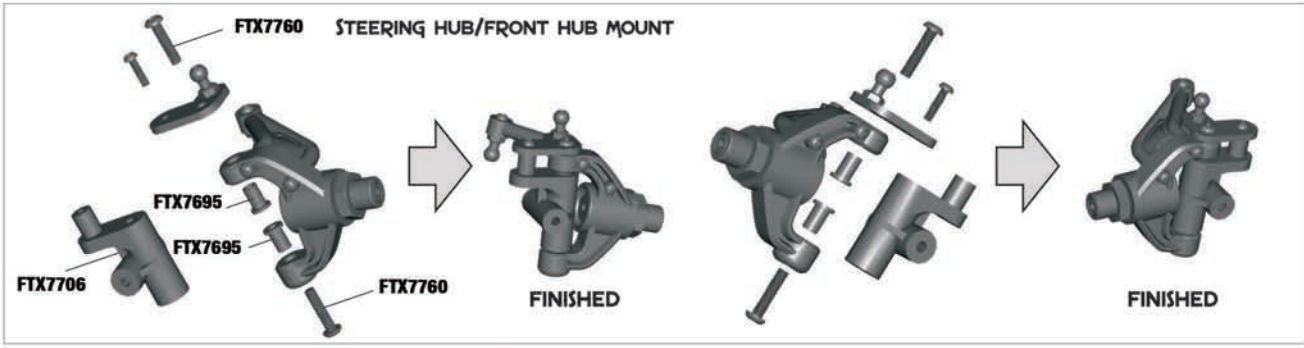



# EXPLODED VIEW

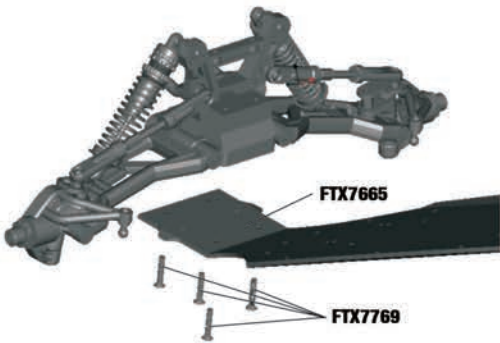

FRONT UNIT INSTALLED TO CHASSIS

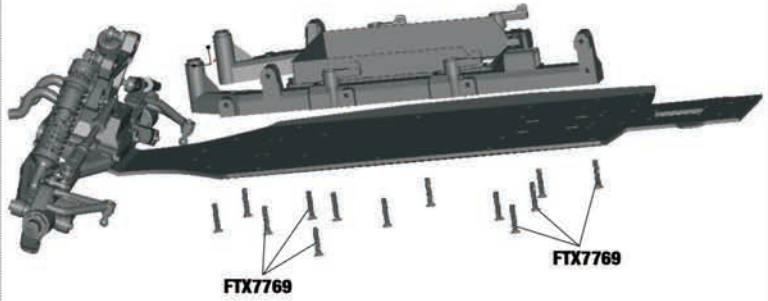

FRONT UNIT INSTALLED TO CHASSIS

## INSTALLING STEERING POSTS

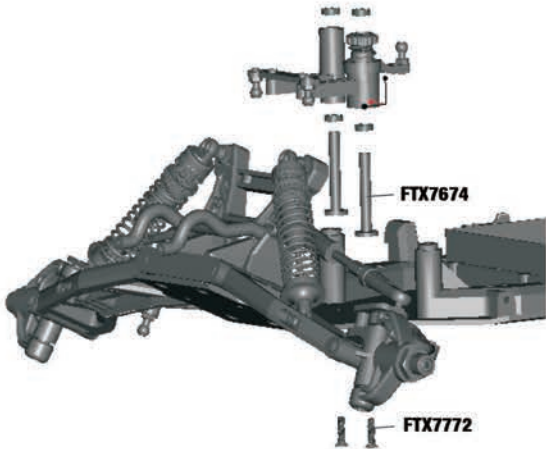

## INSTALLING STEERING TOP PLATE

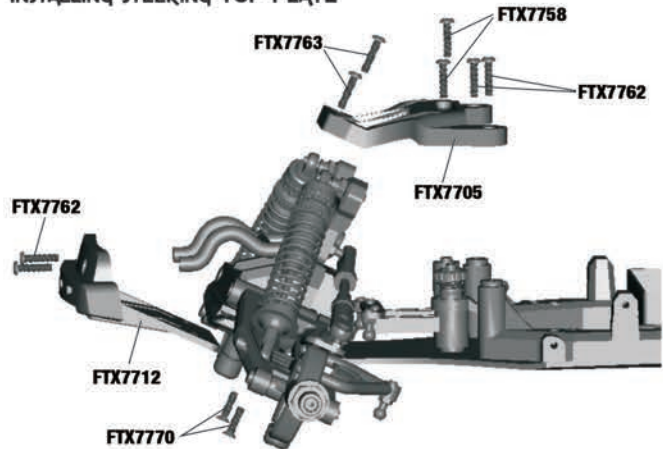

## INSTALLING STEERING LINKAGE SET

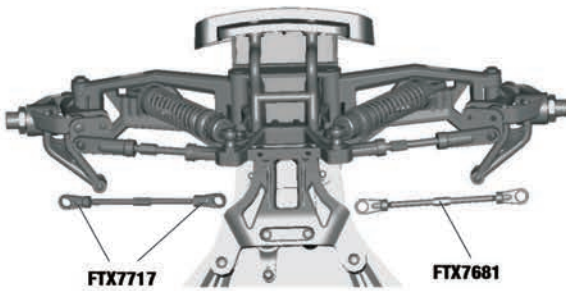

## INSTALLING SERVO

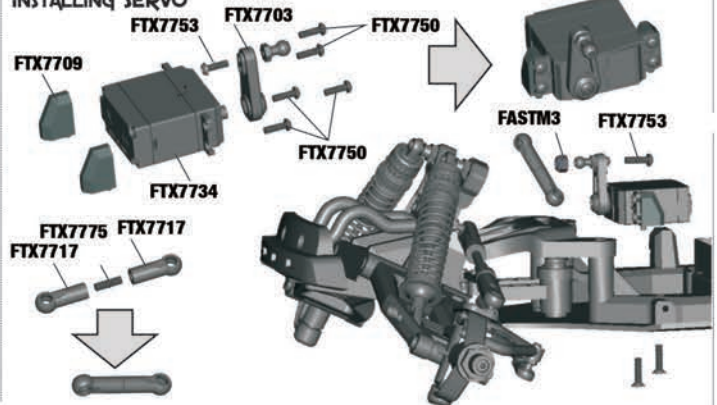

## INSTALLING STEERING TOP PLATE

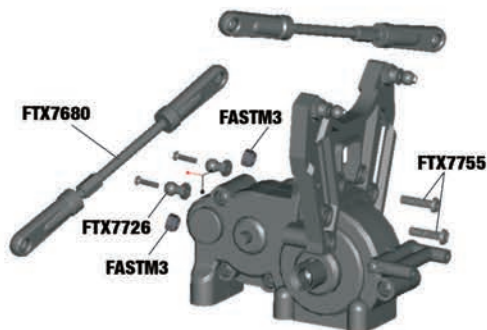

REAR LINKAGE INSTALLATION

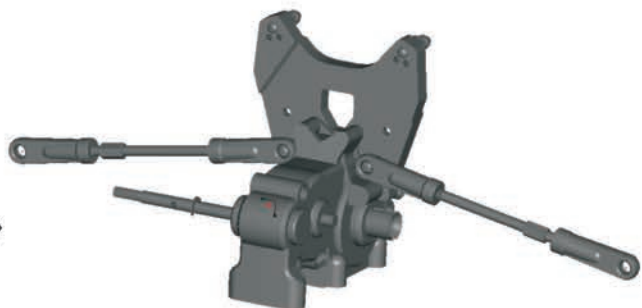



# EXPLODED VIEW

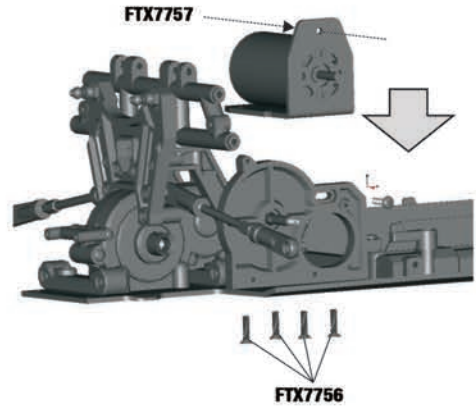
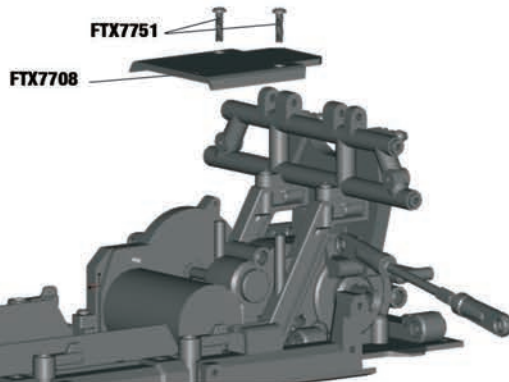
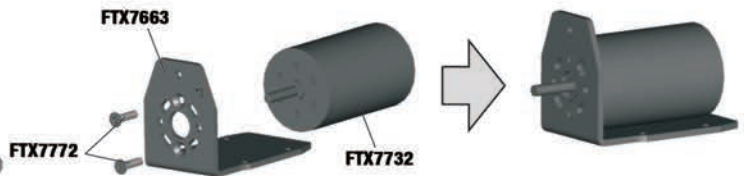
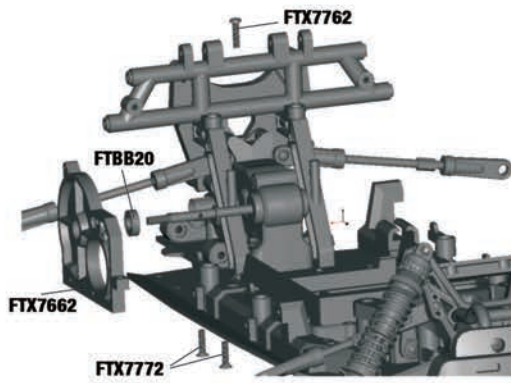
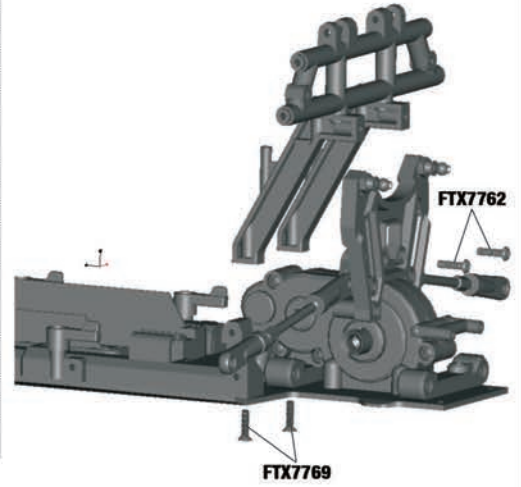
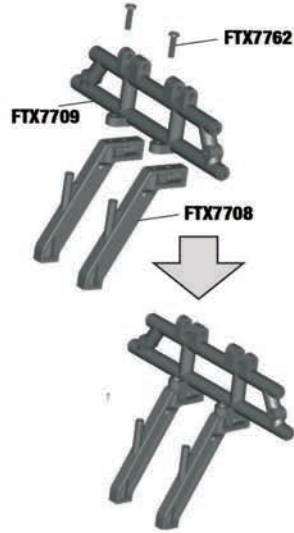
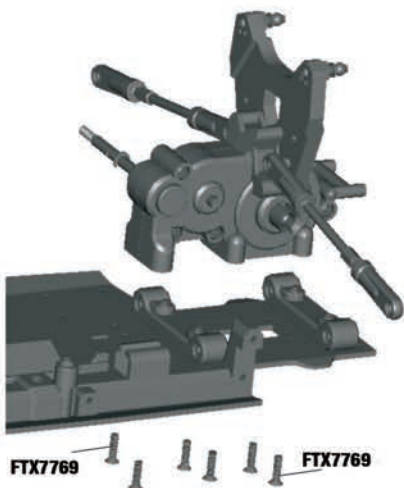
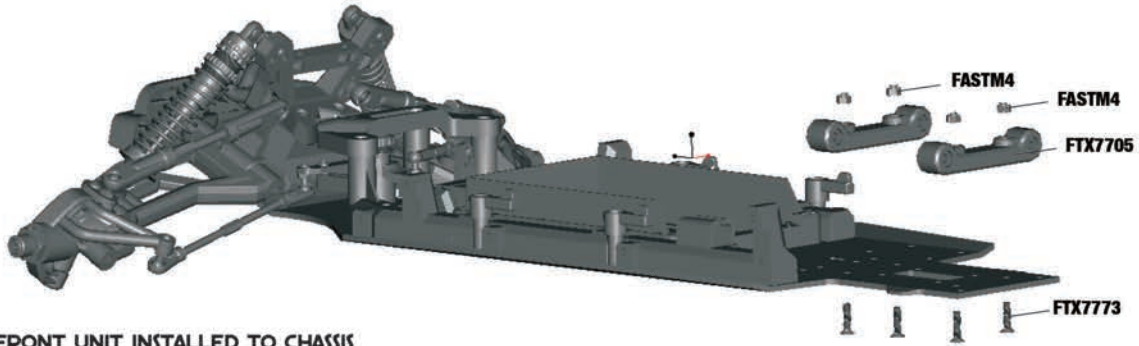



# EXPLODED VIEW

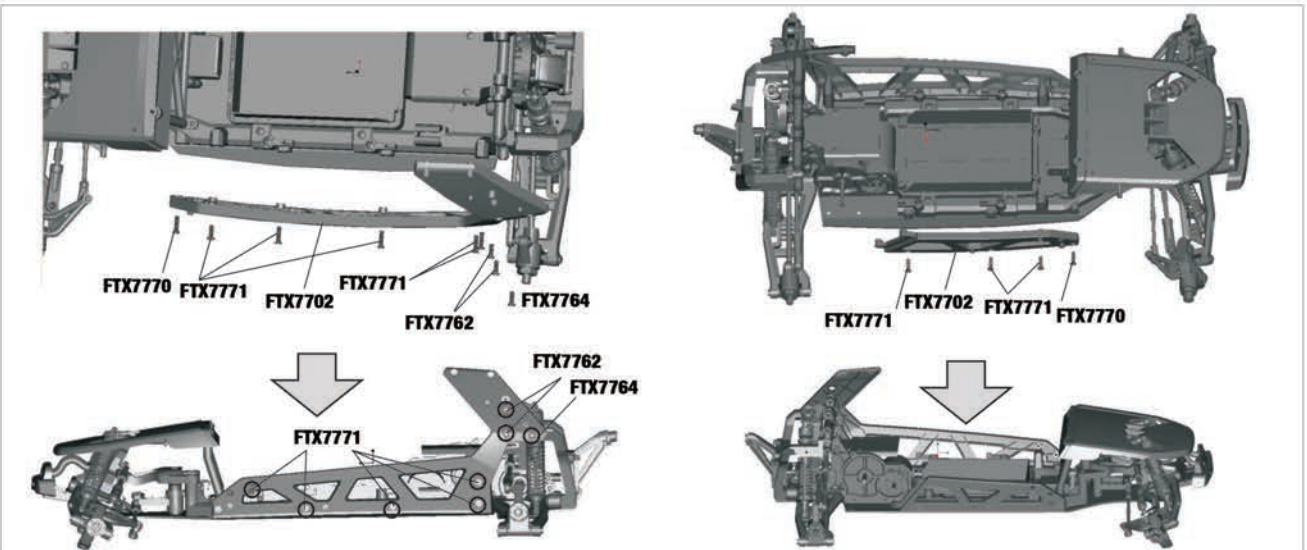
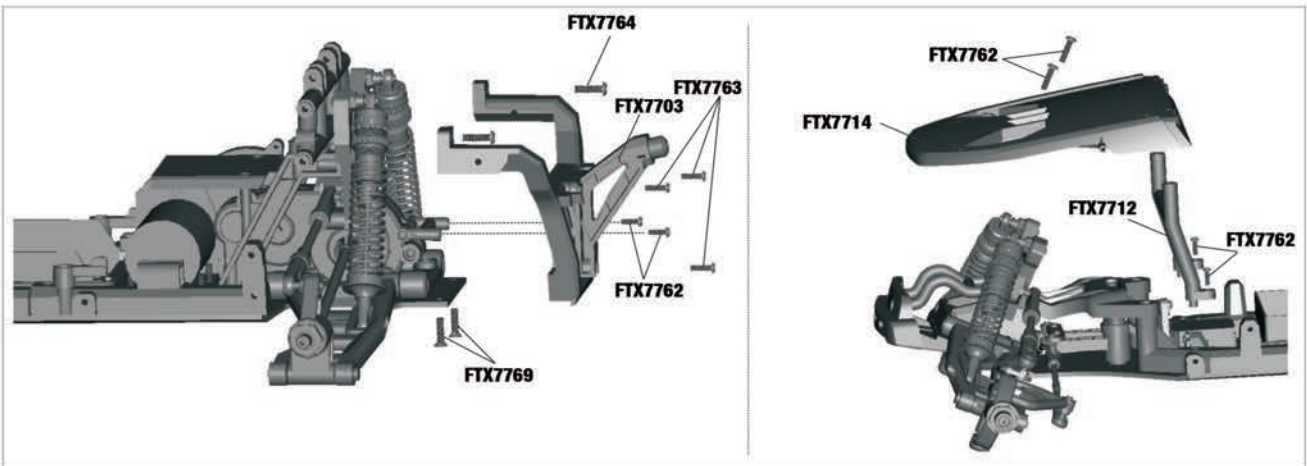
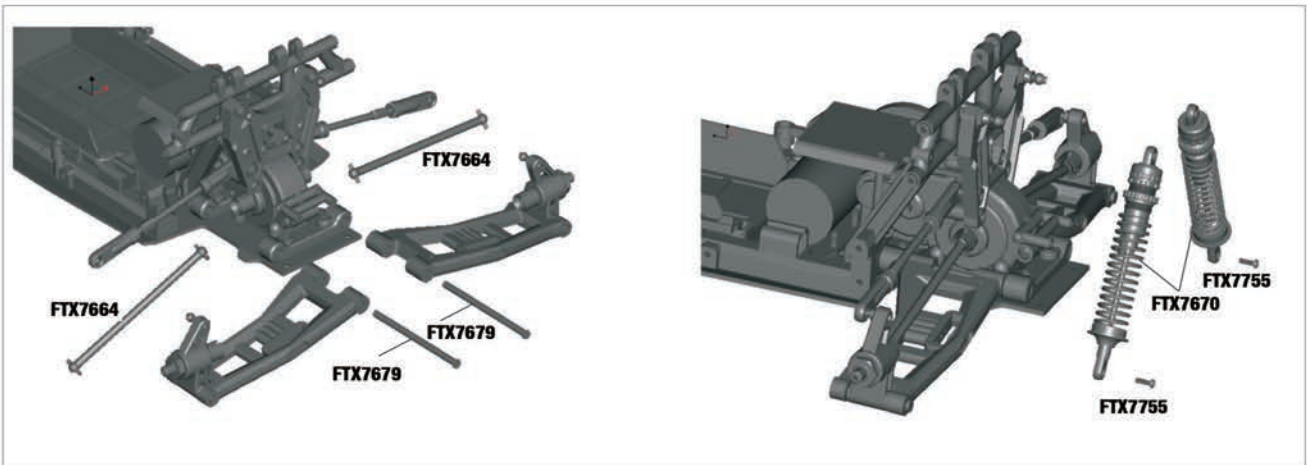



# EXPLODED VIEW

## SIDE BODY INSTALLATION B

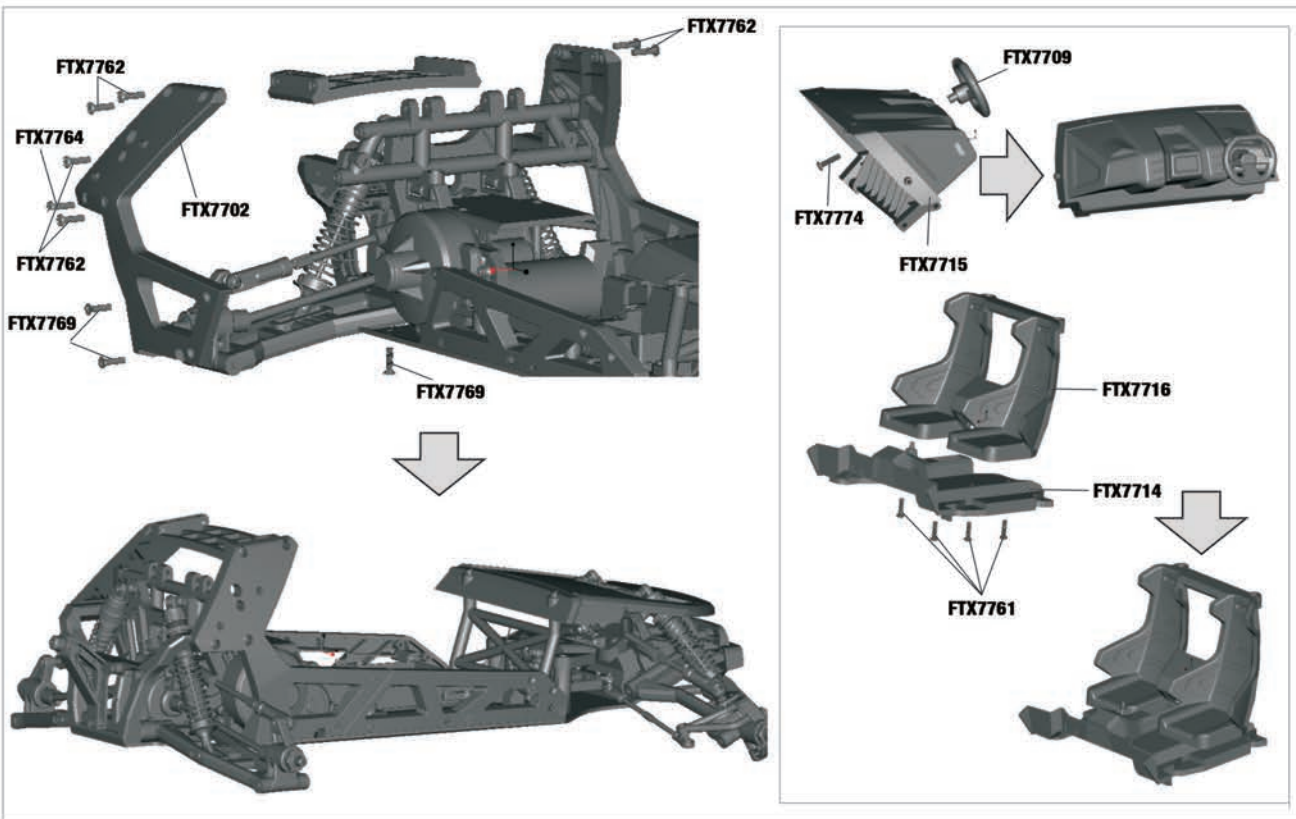
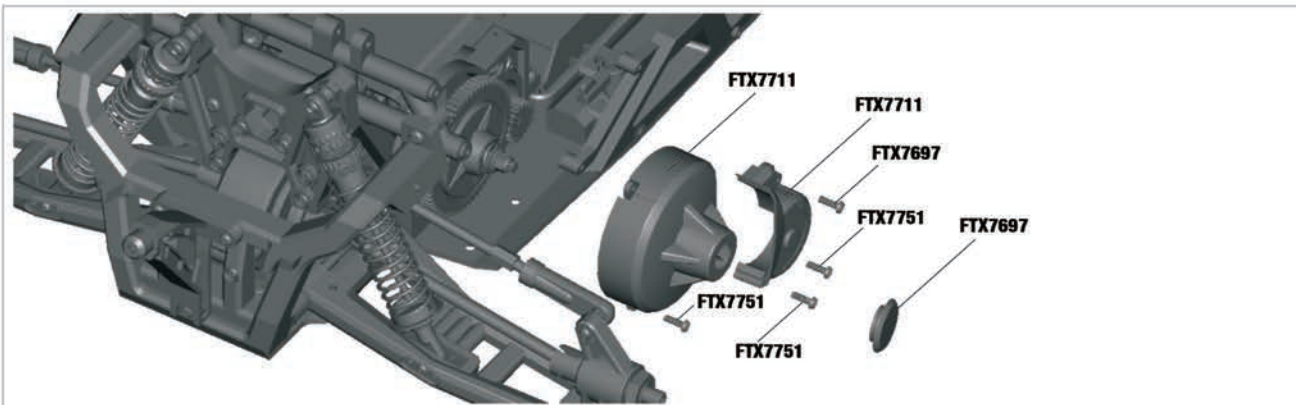
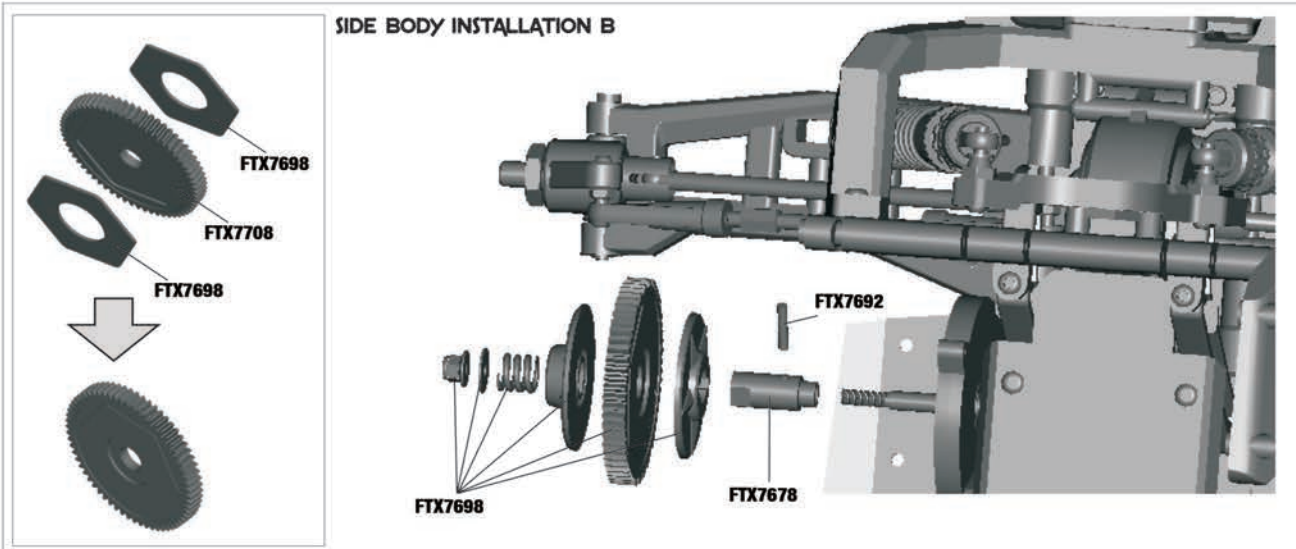



# EXPLODED VIEW

FRONT WINDOW/ SHIELD INSTALLATION

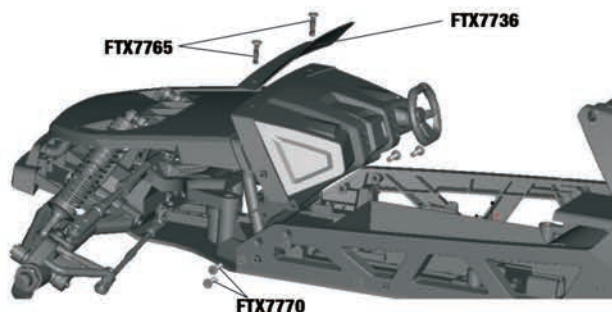

COCKPIT CHAIR INSTALLATION

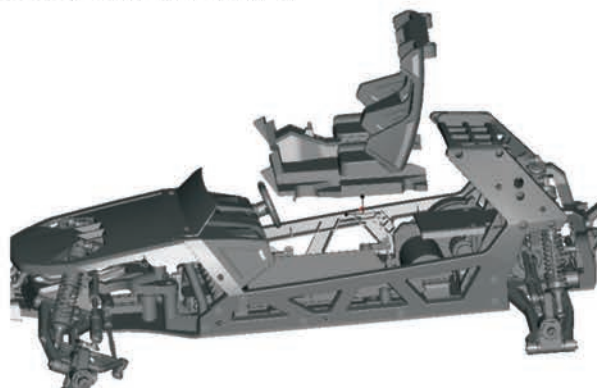

TOP BODY/ROOF INSTALLATION

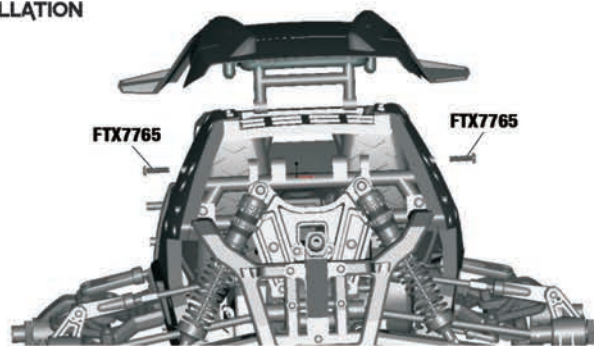
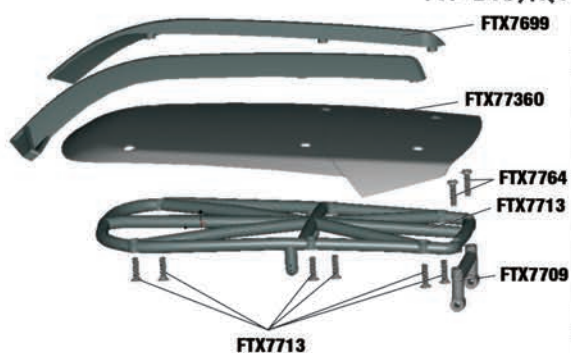

SIDE BODY INSTALLATION A

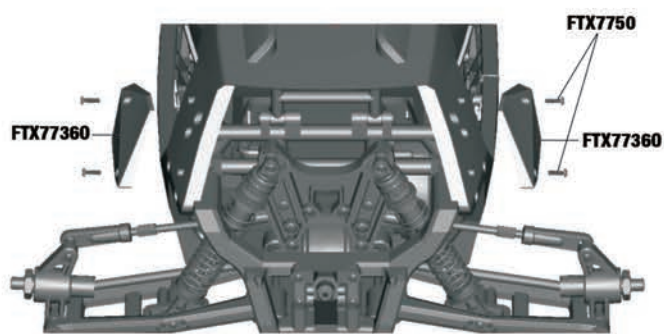

FRONT HOOD INSTALLATION

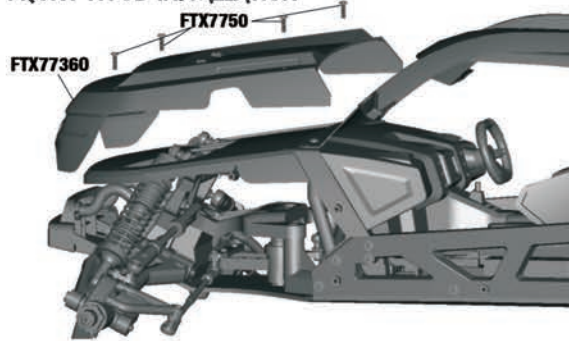

SIDE BODY INSTALLATION B

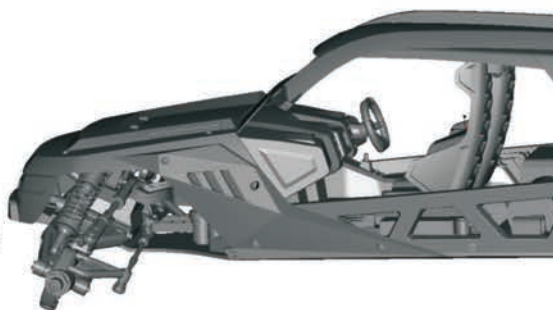





# EXPLODED VIEW

## INSTALLING WHEELS

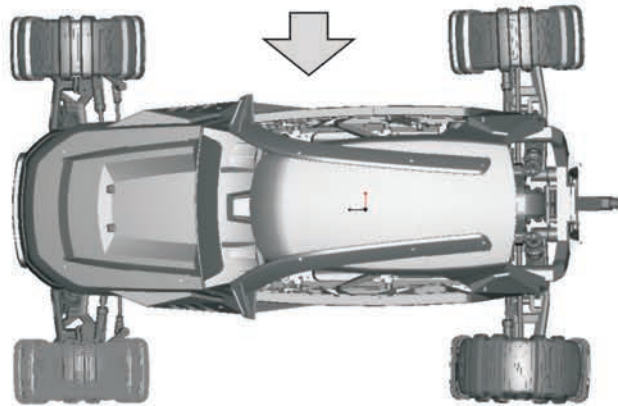

## REAR SPARE WHEEL INSTALLATION

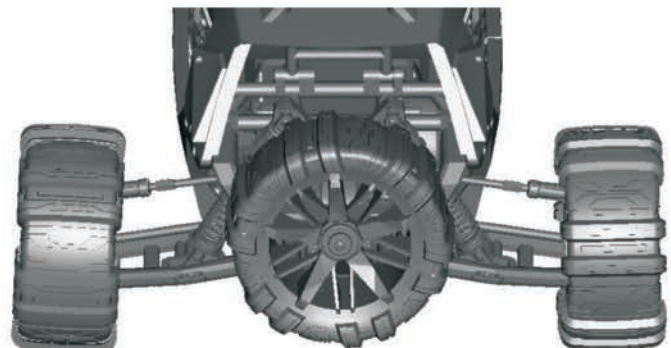
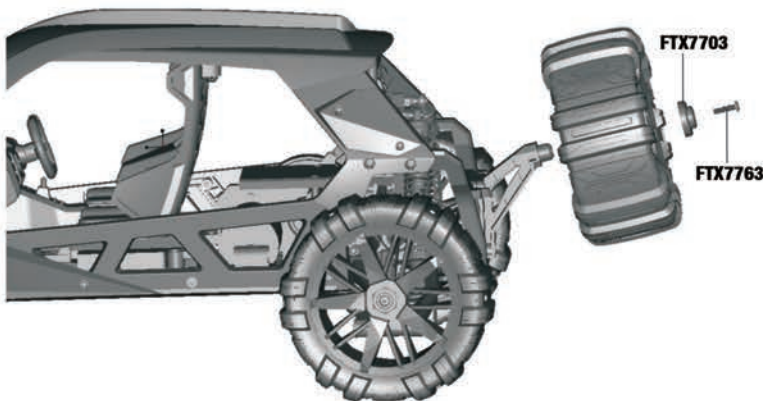



**Notes:**

A large rectangular area containing 25 horizontal dotted lines, intended for writing notes.



**Notes:**

A series of horizontal dotted lines for writing notes, spanning the width of the page.

# FUTURA



[www.ftx-rc.com](http://www.ftx-rc.com)



FTX is an exclusive brand of CML Distribution, Saxon House, Saxon Business Park,  
Hanbury Road, Bromsgrove, Worcestershire, B60 4AD England.  
E-mail: [info@ftx-rc.com](mailto:info@ftx-rc.com)